

INSTALLATION INSTRUCTIONS

**AIRSTREAM TRAILER UNDER-GLOW
LED LIGHT KIT**



Family Owned Motorsports Lighting Since 1989

800.847.1359

www.BoogeyLights.com

Thank you for purchasing genuine Boogey Lights® LED Lighting products! We know you're anxious to get started but we strongly recommend taking time to read through these instructions. You'll likely save yourself some grief and aggravation if you do. For additional installation support refer to www.BoogeyLights.com or give us a call at 800.847.1359 for assistance.

ABOUT THIS GUIDE

OVERVIEW

It's simply not possible to provide detailed instructions for all installation scenarios. The information in this manual is intended to be used as a guide. It's not a 'Step by Step' manual. You may need to vary your installation based on your unique situation. This is particularly the case with electrical wiring and LED mounting/placement. Our light kits provide the essential components needed for a high-quality, functioning lighting system. Installation of our light kit to your specific vehicle may however require changes to the configuration and/or additional items to make it look and fit the way you want.

OTHER ITEMS YOU MIGHT NEED

Before jumping into the installation we have assembled a list of other items you may want to purchase in advance. These aren't essential items but often fall into the "nice to have" category to make the installation look more professional and/or ensure the lights last longer. We offer these items on our website as a convenience to our customers. You can however purchase almost all of these items locally - usually at an auto parts store, hardware store, big box store or home improvement store. Many of them too are available for purchase online elsewhere for less. You can find this list on our website here - ['OTHER ITEMS YOU MIGHT NEED'](https://www.boogeylights.com/other-items-you-might-need/) (https://www.boogeylights.com/other-items-you-might-need/).

THE INSTALLATION

Installation of this led light kit takes 8 to 10 hours depending on whether or not you're installing the Rock-Guard light kit and/or the LED Controller for multi-color LED control.

For the trailer under-glow portion there are nine different mounting locations in this kit and all of the power leads need to be carefully run up to the front of the trailer where we mount our LED controller in the battery box. In some cases it might be necessary to add some aluminum flat bar if the bottom of your trailer doesn't have a suitable smooth, flat mounting surface. That said, our experience with Airstream trailers is you will not need to add aluminum flat bar as long as the bottom of your trailer is clean, smooth and flat. This makes the installation easier and quicker to complete.

If you're adding the rock-guard lights, there are eight additional LED strips (four per rock guard) that need to be mounted under each rock-guard panel (driver's and passenger's side). For multi-color RGB configurations, the LED strips mounted under the trailer are typically wired to ZONE 1 on the LED controller. The rock-guard area LED strips are typically wired to ZONE 2 on the LED Controller. This of course assumes you're installing our DUAL ZONE LED Controller. If not, all of the LEDs will need to be wired to a single zone (or, controlled by a hard wired switch of some kind).

WHAT YOU NEED TO KNOW AND/OR BE ABLE TO DO

In putting together this installation guide we assume the installer has access to and has a basic understanding of using the tools needed to complete this installation properly. We also assume the following:

- The installer understands 12vdc electricity, making electrical connections using crimp on connectors, the importance of having a fuse in the circuit at the battery location and polarity. This manual does not walk you through the electrical connections nor can we provide assistance with same as we are not physically there. We provide a wiring diagram of how the components need to be wired but have to assume the installer knows what he/she is doing in this regard. **If you're unsure about any of this we strongly suggest you ask someone who is to assist you with this part of the installation.**
- How to access the batteries, remove / connect battery connections, how to make electrical connections (e.g. crimping) and the importance of making sure all electrical connections are sealed properly (e.g. no water intrusion).
- How to run cabling such that the power leads and related wiring are secured in a way as to not create a hazard when pulling the trailer.
- Capable of getting under the trailer to mount the LED strips and safely run the power lead connections to the front of the trailer.
- If installing the rock-guard lights, knows how to access the back side of the rock-guard panels. You don't need to take them all the way off. They're on a hinge and can be swung outward from the trailer to provide access to the back side of each panel.
- Capable of assessing your vehicle's battery capacity and on-board charging system. We mention this because in some RVs, the on-board battery capacity and/or charging system is not capable of powering (or sustaining for very long) the number of LEDs being added to the RV. The addition of Boogey Lights LEDs and related LED controller will absolutely increase the drain on your RV's battery. If the battery isn't sized appropriately and/or your on-board charging system can't provide the additional 12vdc power needed to power your LED lighting system, the LEDs will either dim or shut down after a brief use -- or not operate at all.

A Word About Battery Power

One 16' LED strip (300 LEDs) will consume about 3.5 amps on full power brightness (white, max brightness setting). On other colors and lower brightness settings the consumption is considerably less. While most people do not use this max brightness setting for long periods of time, you still need to make sure the 12vdc power source you're using is not only capable of powering the load you're adding, it needs to be able to sustain that load over time. Not all RV chargers/converters/inverters are sized to handle the additional 12vdc electrical load you're now adding to your system. If your batteries and/or converter isn't sufficient to handle the load, the first thing you'll notice is the lights will dim quickly after turning on. Or, they might dim over the course of an hour or so. You can find more information about this issue in our Trouble Shooting Guide here: <https://www.boogeylights.com/trouble-shooting-guide/>.

Selecting the Location for Your LED Controller

As we mentioned previously, we recommend mounting the LED CONTROLLER in the same compartment as your house batteries. This isn't essential but it generally is the most convenient and easiest to do. That said, nothing says you have to mount it there. If you do decide to mount your LED Controller in another location, here are some things to keep in mind:

- While water resistant, the LED controller is not intended to be submerged in water. Mount it someplace where it will not be subjected to the elements.
- Make sure there is enough air flow around the controller. Do not mount it inside a small sealed box without adequate air flow. Doing so will almost certainly mean the controller will shut down (or the lights will dim) when it gets too hot.
- The wireless remote control operates using radio signals (RF or Bluetooth depending upon the model). Where you mount the controller can impact the effective range of the wireless RF remote. For example, mounting the controller near other radio devices (e.g. wireless access point) or mounting it in a compartment that is encased in metal will likely impact the effective range of the remote control. If you're concerned about the reception, we suggest doing some testing of where you mount the controller before permanently mounting it. Our Dual Zone LED controller includes an extended antenna for situations where the effective range of the RF hand held remotes is reduced due to the location where the LED controller is mounted.

BEFORE YOU START

We suggest you carefully review the following before you begin:

1. Make sure you have ample area in which to work and that the area is protected from rain or cold temperatures. The 3M adhesive tape works best if applied when the air temperature is above 40 degrees (and of course is DRY).
2. Make sure you know where your electrical connections will terminate. For this kit most people will mount the LED controller in the battery box at the front of the trailer. While the LED controller is water resistant, it needs to be placed in a location that won't be exposed to the elements. It also needs to be mounted in an area where you have sufficient air flow to keep the LED controller from over-heating.

The LED power leads coming from the LED controller will need to be routed under the trailer and then to each of the LED strips (see layout diagram). We also include some LED power lead feeder cable that can be used to extend the power leads for the LEDs coming out of the LED Controller to the LED strips. See diagram of suggested wiring layout. If you're installing the Rock Guard leds, those power leads will need to connect at the bottom hinged corner of each Rock Guard. Make sure you know how you're going to route these power leads before you start.

3. Bench test your setup. We know this takes a few extra minutes but we **STRONGLY** suggest you bench test your lights **AND** your controller on a table before doing anything further. While we test every light strip and controller before shipping, bench testing your lights will eliminate the possibility of any problems with the lights or controller before mounting. Also, the process of bench testing gives you an opportunity to understand the wiring system without interference from other wires, connectors and cables. You can use any 12vdc battery to do this (e.g. car battery, motorcycle battery, lawn tractor battery or 12vdc power supply). Bench testing takes an extra 10 or 15 minutes. You can also use a common 9vdc battery to test your lights if you don't have a 12vdc bench testing power source available (the lights won't be as bright). It's simple to do and can potentially save you hours of time and frustration down the road. Please take our advice. Bench test your LEDs **AND** controller before mounting.

BTW ... Did we mention we suggest bench **testing your LEDs and** controller before installing? You would be surprised at how many people don't take our advice on this step.

WHAT'S INCLUDED

In addition to the LED Controller (if purchased), LED light strips and power leads, this kit includes some additional items you'll need. Here's a quick review of those items and why we include them. Some of the photos at the end of this guide reference these items too.

- 18AWG (or 20AWG) Feeder Cable – 4 Conductor if RGB, 2 Conductor if Single Color. Use this cable to extend the LED power leads to the LED controller. See the diagram included later on in this document for layout and wiring.
- 3M Adhesion Primer. Used to prep the surface before attaching the LED strips AND the 3M quick-lock tape. *Always, always, always* use this adhesion primer with 3M adhesive products if you want the bond to hold. This includes zip tie mounts.
- 3M VHB double sided tape. This is included IF you purchased the Rock Guard LED light kit. This double sided tape is used to secure the power leads on two of the LED strips (per guard) to the rock guard. Be sure to use 3M adhesion primer first. See photo.
- 3M Quick Lock Reclosable Tape. This is a heavy duty “Velcro like” product. You can use it to mount the LED controller. Be sure to apply 3M Adhesion Primer to the mounting surface and the back of the LED controller.
- Split Wire Loom / ¼”. All power leads need to be protected from the elements and chaffing. Wrap them in this first.
- Split Wire Loom / ½” . We include the ½” split wire loom to be used when you're connecting multiple power leads together. Helps protect that connection.
- Butyl Tape. We use butyl tape to help secure the ends of the power leads where they meet each LED strip to the mounting surface. Butyl will only work if you apply it to a clean surface so make sure you first clean the surface with rubbing alcohol.
- Zip Ties. We include some zip ties which you'll need to secure the LED power leads to the trailer's bottom (zip tie mounts).
- Zip Tie Mounts. Used to secure the power leads to the trailer's bottom. Be sure to use 3M adhesion primer first.
- Crimp On Wire Connectors. These are used to secure the wire connectors at the LED Controller as well as making all power lead connectors to the feeder cable. We recommend wrapping each connector after it's crimped with electrical tape and then split-loom to protect it from water intrusion. If you prefer to twist your cable connections together (vs using the crimp on connectors), you can use heat shrink to seal those connections.
- Heat Shrink. We like to seal our battery connections (battery lugs) and power lead connectors with heat shrink where possible. It's not essential but helps with water intrusion into the connections.

NOTE: Every installation varies a little so you may need to purchase additional items for your install.

Cutting Your LEDs

If you need to cut your LED strip you can do so as long as you cut in the proper location – which is every three LEDs as shown in the below photo. Cutting incorrectly could damage your lights and is not covered by the warranty. If you cut the strip, be sure to seal the cut end. You can use heat shrink or silicone found at your local hardware or RV store. If you do need to cut your LED strip, we strongly suggest doing so BEFORE you mount the strip.

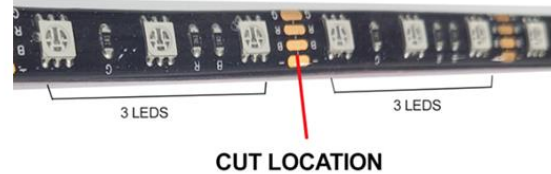

Mounting Your LEDs

- The area where you are mounting the LEDs must be clean: free of all dirt, oil or anything that might affect the LED from sticking. You only get one opportunity to mount the LEDs so it's critical the area be prepared properly.
- Use rubbing alcohol to clean the area where you are going to mount the LED strip. Be sure to let the alcohol dry completely before proceeding to the next step. (Note: Do not use acetone or similar cleaner).
- Next, use the 3M Adhesion Promoter supplied with your kit to "paint" on the promoter where you are going to mount the LED strip. **This is an important step. Do not bypass.** Allow the promoter to dry for 60-90 seconds.
- Peel off the red backing tape that protects the 3M adhesive tape on your LED strip. Be careful not to let the tape touch anything. The 3M backing tape on these LED strips are one-use only. They cannot be reused.

Do NOT bend the LED strip in a radius of less than 2 inches.



Do NOT bend the LED strip on a horizontal plane.



Carefully push the LED strip to the area you have prepared. You will want to apply only enough pressure to the strip to make sure it is firmly mounted. *You only get one opportunity to do this.* Once the LED strip touches a properly prepared surface that has been promoted, that LED strip will be very difficult to remove. Moreover, if you do remove the LED strip, the strip cannot be used again without adding another layer of 3M adhesive tape to the back.

DO NOT press too hard as too much pressure can damage the LEDs and connecting wires in the strip. Also, do not pull, stretch or twist the LED strip. Too much tension on the strip will also damage the LEDs such that some of the LEDs in the strip will not illuminate. The strip must be mounted flat against a single continuous mounting surface, in a straight line. Really important that the ENTIRE STRIP be stuck to the mounting surface and that you NOT attempt to span across multiple mounting surfaces.

LED PLACEMENT

We recommend mounting the LED strips as indicated on the diagram on the next page (note: the red line on the layout diagrams indicates where the feeder cable is required.) That said, nothing says you have to follow this layout exactly. If your trailer for example isn't the same exact layout or dimensions you can adjust and/or cut (or even add strips) if you want. Regardless, before proceeding, it's super important to understand that these LED strips cannot be mounted in such a way as they span multiple surfaces. They must be mounted on a smooth, flat, continuous rigid mounting surface. Spanning two mounting surfaces on a vehicle that moves, flexes and vibrates will absolutely not work. The LED strip will fail and they will do so sooner rather than later; we can almost guarantee it. We know the temptation is there because it's easy/fast to do BUT you're going to be disappointed if you do. Mounting the LED strip across multiple surfaces will void the warranty as well. Also, do not attempt to mount the strip to follow a radius. The LED strip has to be mounted in a straight line.

We have a number of installation related videos on our website (and Youtube channel) which many customers find helpful. Here are some links (they can also be found on our INSTALLATION RESOURCES page). Even though some of the videos might not be of an under-glow kit install for your specific RV model, the wiring and LED controller mounting are similar for most all installations.

<https://www.boogeylights.com/how-to-videos/>

<https://www.boogeylights.com/video-how-to-install-led-awning-light-on-any-travel-trailer/>

<https://www.boogeylights.com/video-how-to-install-a-boogey-lights-multi-color-under-glow-led-light-kit/>

You can also view additional videos on our Youtube channel here:

<https://www.youtube.com/c/BoogeyLightsLEDs/>

SUGGESTION: Before closing/wrapping all electrical connections we strongly suggest testing the lighting system. Nothing is more frustrating than closing up all connections, making it look nice only to find out moments later something isn't working correctly. Don't ask us how we know.

QUESTIONS? If you have questions about the installation, give us a call at 800.847.1359. We'll be happy to talk through your installation over the phone.

UNDER-GLOW FULL PERIMETER | 26' U AIRSTREAM TRAILER

(not to scale. for general placement demonstration only)

Forward Door

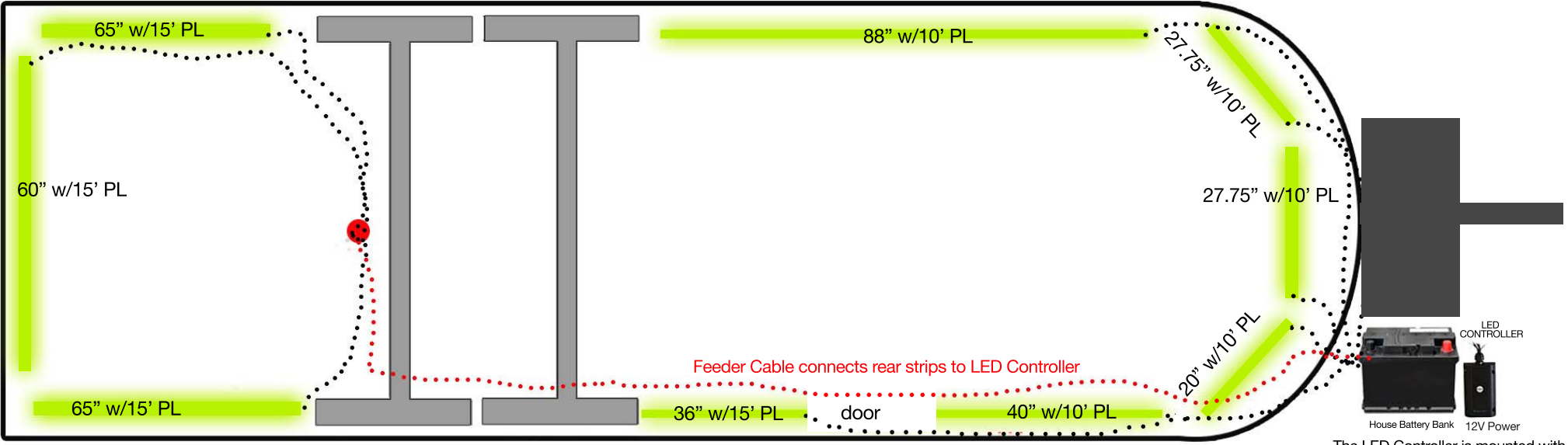

The LED Controller is mounted with the house batteries.

All power leads must run back to the Boogey Lights LED controller mounted at or near the 12vdc power source. We always recommend using the house batteries as the power source. **IMPORTANT! LED strips can not "daisy chain" from one strip to the next.** NOTE: LED Strips can be cut every third LED if you need shorter lengths.

- IF DUAL ZONE
- ZONE 1: The trailer under-glow power leads are connected to zone 1.
 - ZONE 2: The rock-guard LEDs are connected to zone 2.

UNDER-GLOW FULL PERIMETER | 27' AIRSTREAM TRAILER

(not to scale, for general placement demonstration only)

Globetrotter / Rear Door

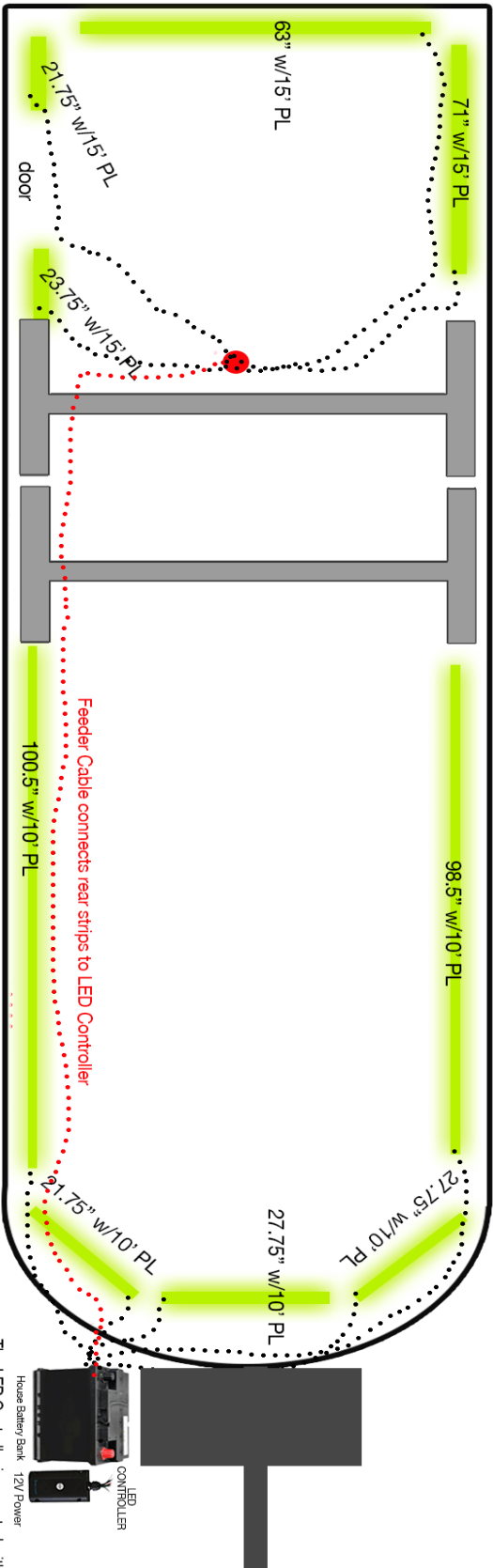

All power leads must run back to the Boogey Lights LED controller mounted at or near the 12vdc power source. We always recommend using the house batteries as the power source. **IMPORTANT!** LED strips can not "daisy chain" from one strip to the next. NOTE: LED Strips can be cut every third LED if you need shorter lengths.

IF DUAL ZONE

ZONE 1: The trailer under-glow power leads are connected to zone 1.

ZONE 2: The rock-guard LEDs are connected to zone 2.

Not all models have the door at the rear like this 27' GLOBETROTTER, If your trailer doesn't, we can adjust the LED Lengths to fit. Contact us with your measurements for the passenger's side lengths.

3 September 2021

UNDER-GLOW FULL PERIMETER | 30' AIRSTREAM TRAILER

Forward Door

(not to scale, for general placement demonstration only)

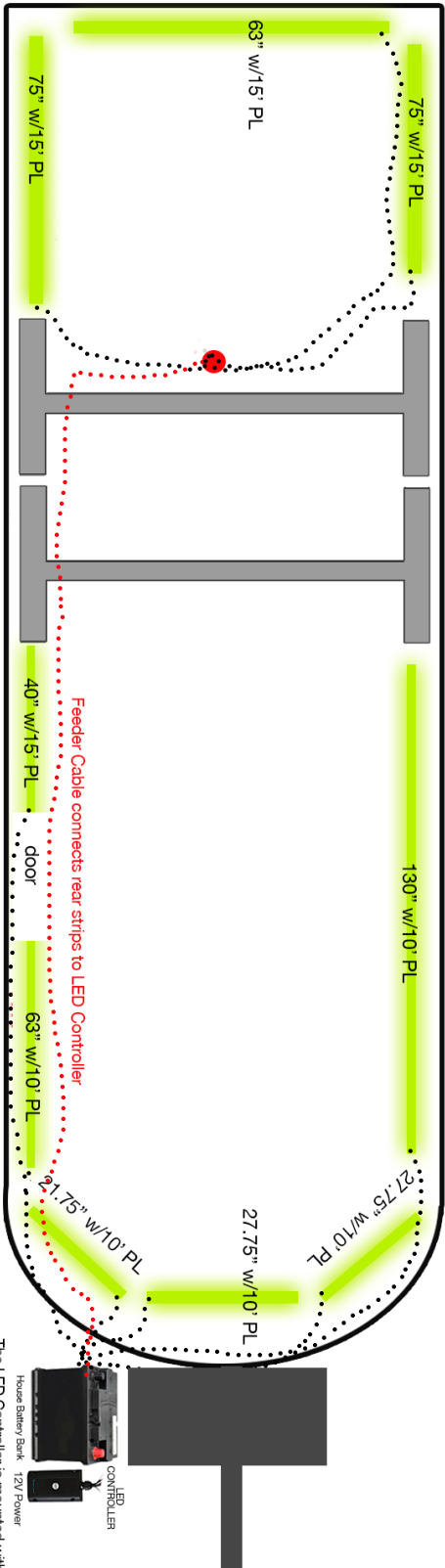

All power leads must run back to the Boogey Lights LED controller mounted at or near the 12vdc power source. We always recommend using the house batteries as the power source. **IMPORTANT!** LED strips can not "daisy chain" from one strip to the next. NOTE: LED Strips can be cut every third LED if you need shorter lengths.

IF DUAL ZONE

ZONE 1: The trailer under-glow power leads are connected to zone 1.

ZONE 2: The rock-guard LEDs are connected to zone 2.

Not all models have the door in the front like this 30' trailer. If your trailer doesn't, we can adjust the LED Lengths to fit. Contact us with your measurements for the passenger's side lengths.

18 November 2021

UNDER-GLOW FULL PERIMETER | 33' AIRSTREAM TRAILER

Forward Door

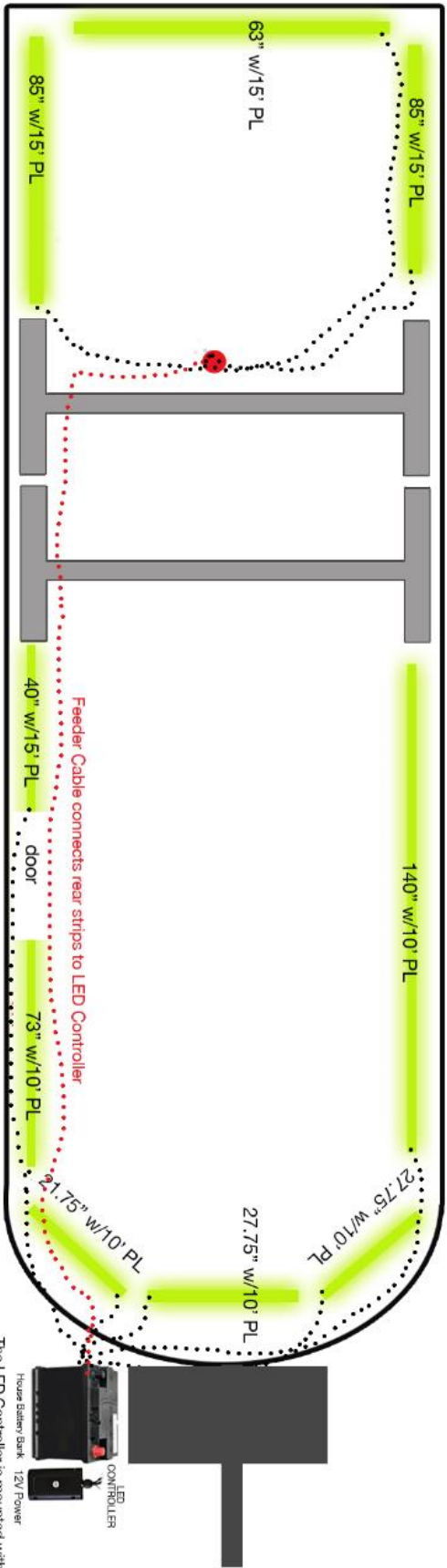

All power leads must run back to the Boogey Lights LED controller mounted at or near the 12vdc power source. We always recommend using the house batteries as the power source. **IMPORTANT!** LED strips can not "daisy chain" from one strip to the next. NOTE: LED Strips can be cut every third LED if you need shorter lengths.

- IF DUAL ZONE
- ZONE 1: The trailer under-glow power leads are connected to zone 1.
- ZONE 2: The rock-guard LEDs are connected to zone 2.

ROCK GUARD

Mounting the LEDs on each Rock Guard requires that you first unbolt the non-hinged sides of the rock guard. It will swing outward like you see in our photo below which exposes the rear of the rock guard. Two of the LED strips can be mounted such that the power leads come out at the bottom of the rock guard where the hinge is located. The other two power leads however need to be secured to the rock guard using 3M VHB tape so they can then be routed down to the same location as the other two power leads. Be sure to prepare all surfaces using rubbing alcohol and 3M adhesion primer. Then, affix the 3M VHB tape to the rock guard. Finally, firmly press the power lead cable (wrapped in ¼" split-loom first) from the other two LED strips to the 3M VHB tape such that the power lead cables meet at the bottom of the rock guard, at the hinged edge. All four power leads can then be routed together to the LED controller.

Rock Guard View Inside. Passenger's Side

